

# SUSSEX

Product Code: DUT-04a

Duet Progressive Wall Basin Mixer System 165mm

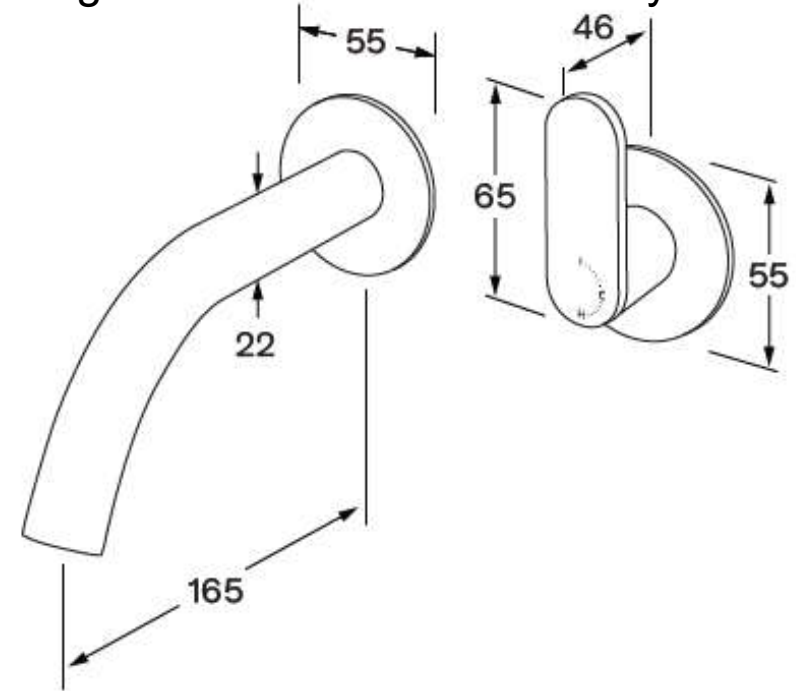

### Product features

- Designed and manufactured in Australia
- All brass construction
- Progressive mixer brass cartridge
- Incorporating Sussex Masterfit
- Available in a range of high quality, durable finishes inc. LUXPVD®
- Minimal, refined design to complement any contemporary space
- Matching tapware and showers

### Warranty

15 Year overall warranty.  
Refer to Warranty sheet for specific information.

### Pressure rating

300 - 500kPa

### Temperature rating

1 - 65°C

### WELS rating

6 star - 4.5lt/min

# ACS

1300 898 889

[www.acsbathrooms.com.au](http://www.acsbathrooms.com.au)



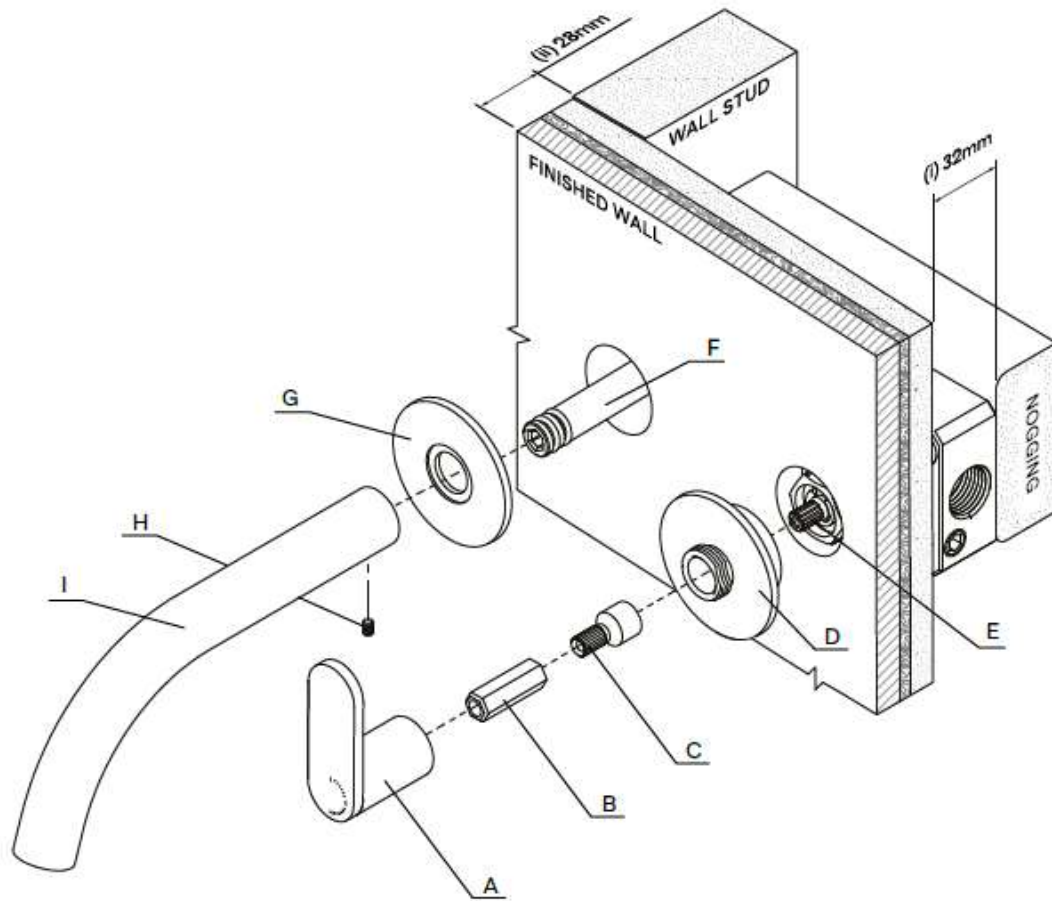

#### Rough-in:

- The In-wall (Body Mixer) is supplied and is to be used in conjunction with this Tapware.
- Secure a nogging 32mm (i) back from the front of the stud. Attach the Wall Body Mixer to the nogging.
- Ensure the Body Mixer mounted is square and parallel between the Wall Studs.
- For the purpose of the illustration, the thickness of the finished Wall coverings is calculated to be 28mm (ii)
- See step 1 for rough in configuration.

#### Product parts

- (A) Handle
- (B) Spindle Adapter
- (C) Spindle Extension
- (D) Dress Ring
- (E) Spindle
- (F) Supply Post
- (G) Dress Ring (Outlet)
- (H) Set Screw
- (I) Outlet

#### Plumber note

- Tapware is to be installed by a Licensed Plumber in accordance with AS/NZS 3500:2021
- Recommended working water pressure 300 - 500 Kpa. Maximum water temperature is 65°C
- After installation, ensure that tapware functions correctly without leaks.
- Please ensure a copy of the Installation Instructions are left with the end user for future reference.

#### Pressure testing

On-site high pressure line testing must be conducted with the Mixer in the closed position. (STATIC TEST ONLY)  
Under no circumstances is the Mixer to be opened when exceeding the maximum stated water pressure.  
At the completion of the testing, do not relieve any high pressure by opening the Mixer.  
Exposing the internals of the Mixer Cartridge to higher than specified water pressures, will void the manufacturer's warranty

