

moda

Code: A-120B

Material: Isostone - 70% Limestone Composite

Size: W 1600 x D 700 x H 580 mm

Warranty: 10 Years

Features:

- Smooth solid matt white finish (gloss by custom order)
 - Italian Design & Engineering
 - Superior Heat Retention
 - Pop Up Waste - Installed
 - 1mtr Flexible Drain Hose for Easy Installation (DN40)
 - Galvanised Metal Base Support
 - Adjustable Leg Height For Levelling
 - Scratch and Stain resistance
 - Repairable Material
 - Australian Standard (SAI)
- AS/NZS 3718:2003

Rosa

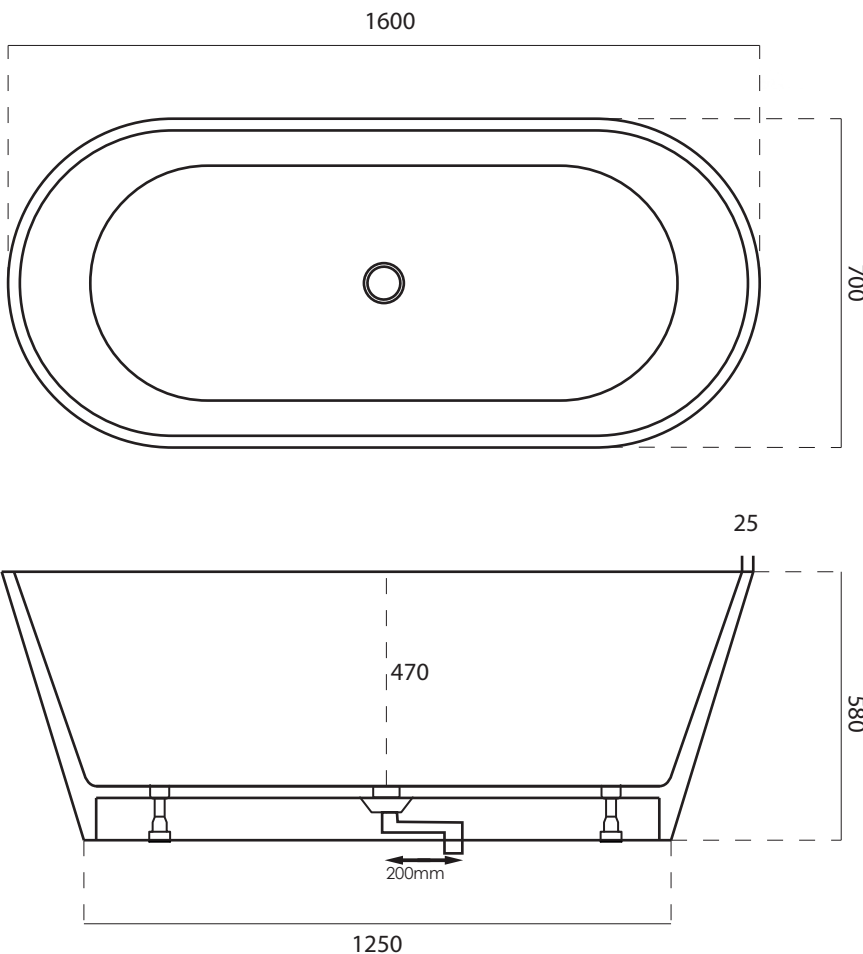

Specifications:

- Net Weight: 145Kg
- Crate size:
L 1700, W 800, H 830mm
- Gross Weight: 175Kg



ACS

DESIGNER BATHROOMS

1300 898 889

www.acsbathrooms.com.au