

# moda

## Code: A-123T

**Material:** Isostone - 70% Limestone Composite

**Size:** W 1755 x D 900 x H 540 mm

**Warranty:** 10 Years

### Features:

- Smooth solid matt white finish (gloss by custom order)
- Italian Design & Engineering
- Superior Heat Retention
- Pop Up Waste - Installed
- 1mtr Flexible Drain Hose for Easy Installation (DN40)
- Galvanised Metal Base Support
- Adjustable Leg Height For Levelling
- Scratch and Stain resistance
- Repairable Material
- Australian Standard (SAI)  
AS/NZS 3718:2003

## Lucia Thick

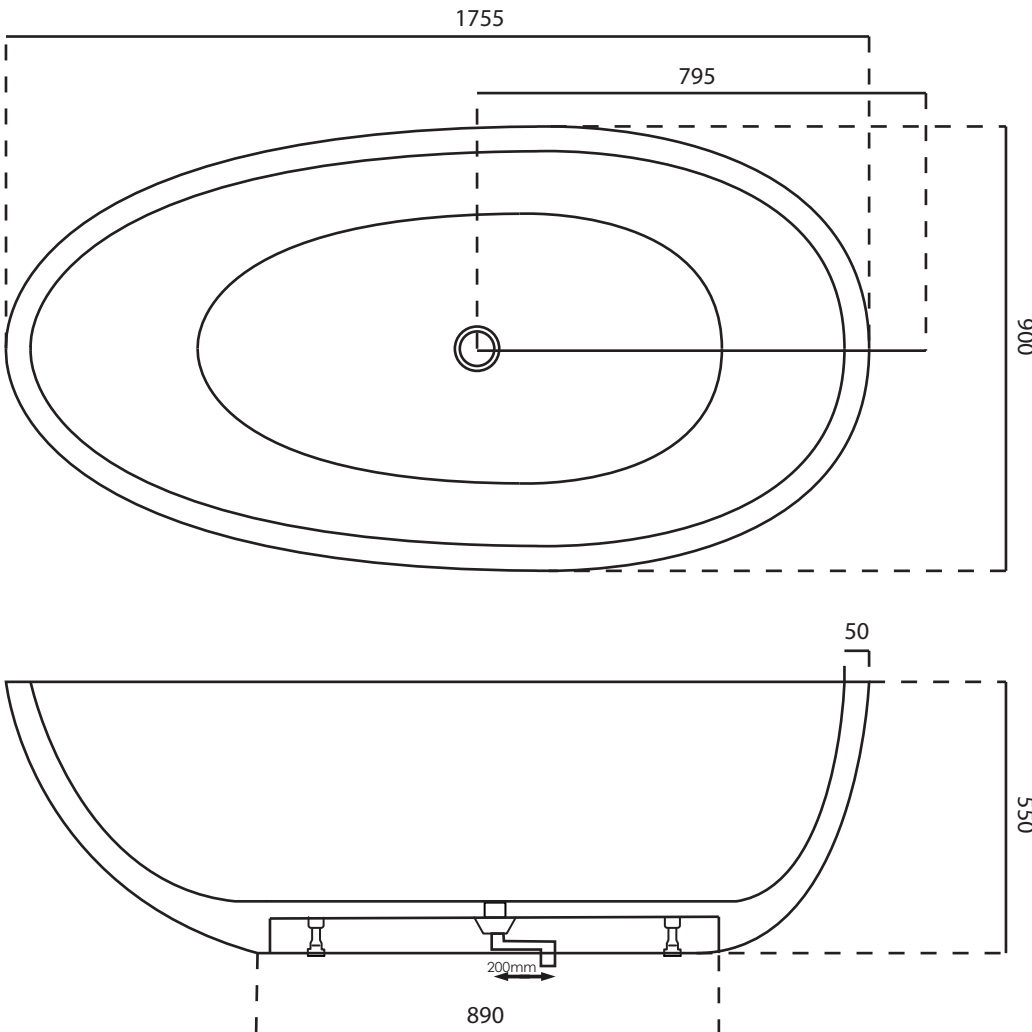

### Specifications:

- Net Weight: 168Kg
- Crate size:  
L 1805, W 950, H 590mm
- Gross Weight: 198Kg



# ACS

DESIGNER BATHROOMS

1300 898 889

[www.acsbathrooms.com.au](http://www.acsbathrooms.com.au)