

# moda

## Code: A-123B

**Material:** Isostone - 70% Limestone Composite

**Size:** W 1700 x D 870 x H 550 mm

**Warranty:** 10 Years

### Features:

- Smooth solid matt white finish (gloss by custom order)
  - Italian Design & Engineering
  - Superior Heat Retention
  - Pop Up Waste - Installed
  - 1mtr Flexible Drain Hose for Easy Installation (DN40)
  - Galvanised Metal Base Support
  - Adjustable Leg Height For Levelling
  - Scratch and Stain resistance
  - Repairable Material
  - Australian Standard (SAI)
- AS/NZS 3718:2003

## Lucia

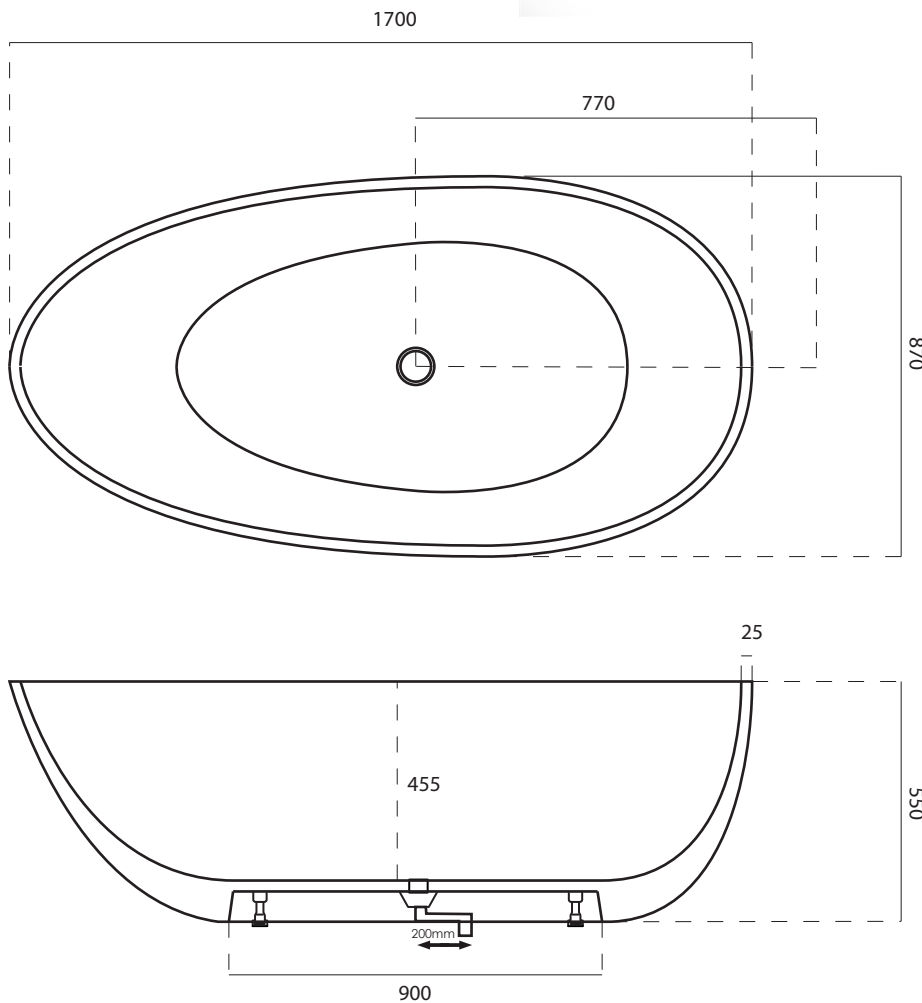

### Specifications:

- Net Weight: 152Kg
- Crate size:  
L 1800, W 970, H 750mm
- Gross Weight: 182Kg



# ACS

DESIGNER BATHROOMS

1300 898 889

[www.acsbathrooms.com.au](http://www.acsbathrooms.com.au)