

moda

Code: A-124

Material: Isostone - 70% Limestone Composite

Size: W 1820 x D 920 x H 520 mm

Warranty: 10 Years

Features:

- Smooth solid matt white finish (gloss by custom order)
- Italian Design & Engineering
- Superior Heat Retention
- Pop Up Waste - Installed
- 1mtr Flexible Drain Hose for Easy Installation (DN40)
- Galvanised Metal Base Support
- Adjustable Leg Height For Levelling
- Scratch and Stain resistance
- Repairable Material
- Australian Standard (SAI)
AS/NZS 3718:2003

Italia

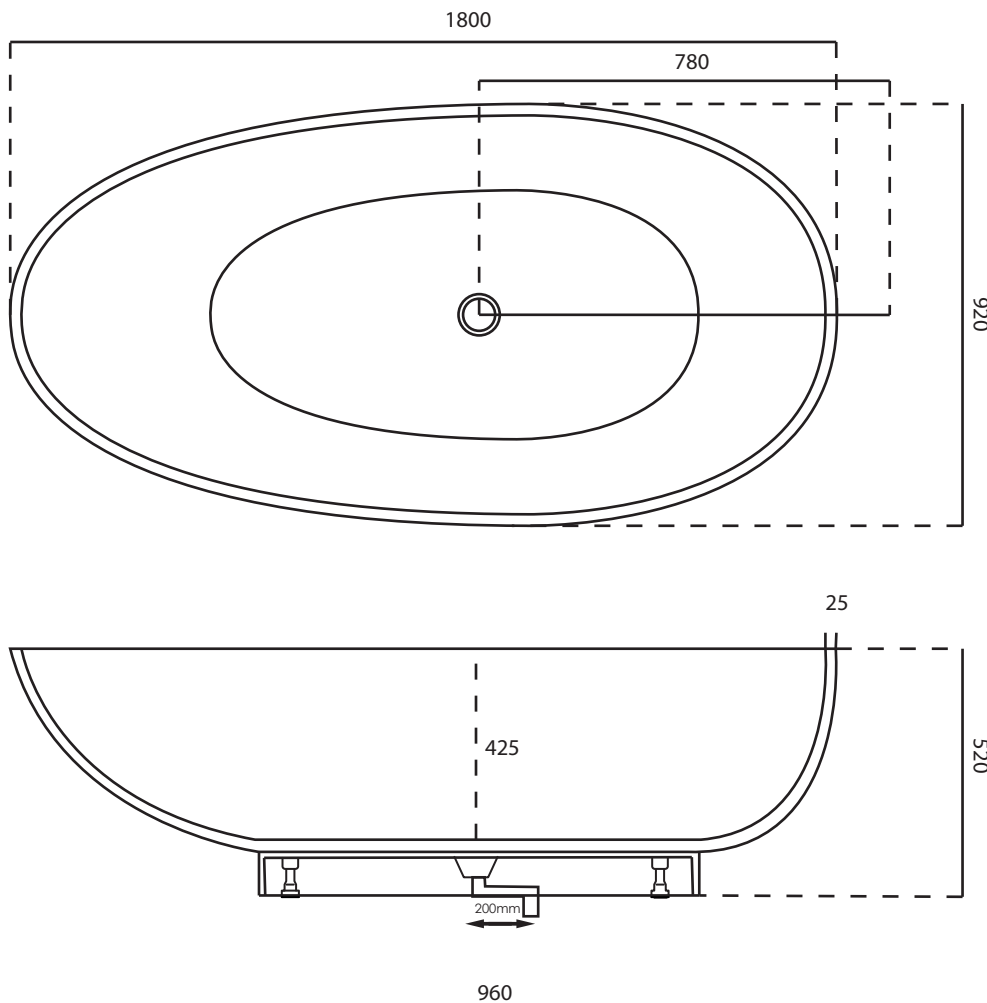

Specifications:

- Net Weight: 160Kg
- Crate size:
L 1920, W 1020, H 720mm
- Gross Weight: 190Kg



ACS

DESIGNER BATHROOMS

1300 898 889

www.acsbathrooms.com.au