

moda

Code: A-137

Material: Isostone - 70% Limestone Composite

Size: W 1650 x D 800 x H 580 mm

Warranty: 10 Years

Features:

- Smooth matt white finish (gloss by custom order)
- Italian Design & Engineering
- Superior Heat Retention
- Pop Up Waste – Installed
- 1mtr Flexible Drain Hose for Easy Installation (DN40)
- Scratch and Stain resistance
- Adjustable Leg Height For Levelling
- Repairable Material
- Australian Standard (SAI) AS/NZS 3718:2003

Kim

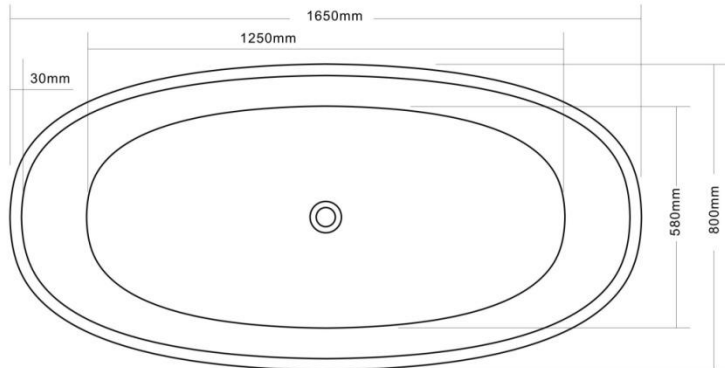

Specifications:

- Net Weight: 160Kg
- Crate size:
L 1750, W 900, H 605mm
- Gross Weight: 175Kg

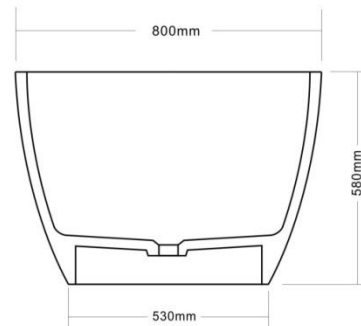
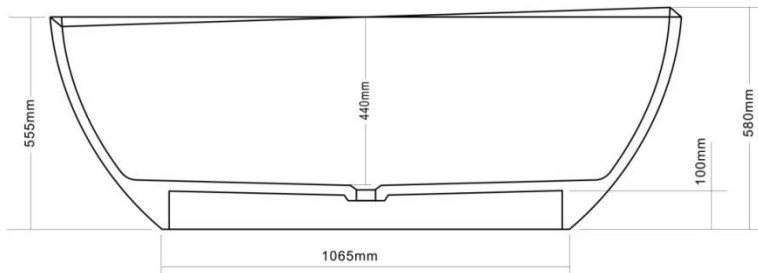

ACS
DESIGNER BATHROOMS

1300 898 889

www.acsbathrooms.com.au