

moda

Code: A-139A

Material: Isostone - 70% Limestone Composite

Size: W 1700 x D 700 x H 620 mm

Warranty: 10 Years

Features:

- Freestanding Bath with Metal Legs
- Smooth matt white finish (gloss by custom order)
- Italian Design & Engineering
- Available in Matt Black & Satin Brass legs
- Superior Heat Retention
- Scratch and Stain resistance
- Repairable Material
- Australian Standard (SAI) AS/NZS 3718:2003

ISABELLA

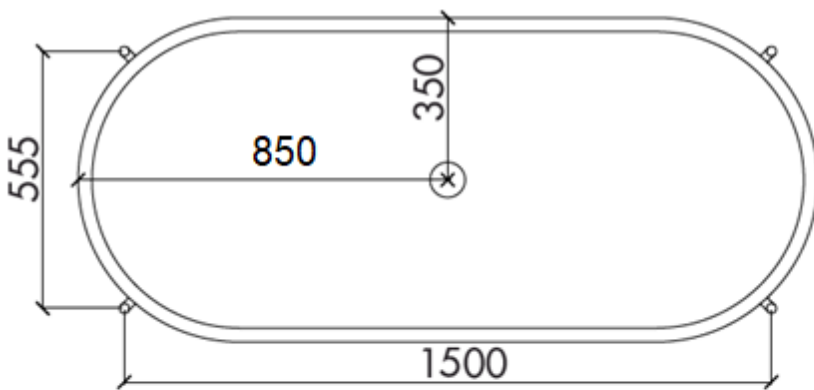
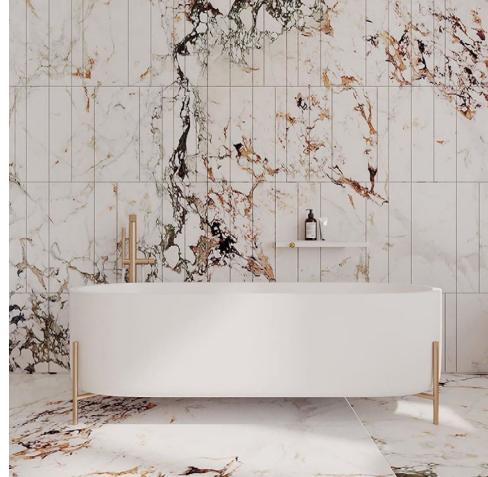

Specifications:

- Net Weight: 140Kg
- Crate size: L 1810, W 810, H 645mm
- Gross Weight: 160Kg

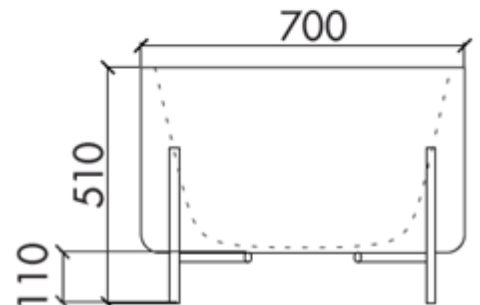
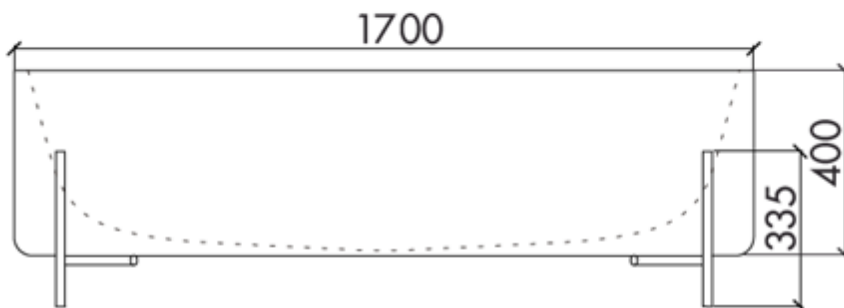

ACS
DESIGNER BATHROOMS

1300 898 889

www.acsbathrooms.com.au

As part of ACS commitment to quality products. Information provided in this data sheet is representative of the actual product available at the time of printing. Due to our commitment to continuous product design and development, the designs and specifications depicted are subject to change without notice. Please confirm all particulars with your ACS sales consultant prior to purchase. Each product is covered by a limited warranty. Please see our website for full terms and conditions. This drawing remains the property of ACS and should not be copied or distributed without ACS consent. © 2010 All Dimensions are approximate in mm and are not to scale.