

The last bastion of privacy, a space of peace and tranquillity, your Bathroom
 Enjoy the look and feel of our European Bathroom fittings and fixtures.
 Designed and made to the highest International and Australian standards.



moda

ELLIPSIS FREESTANDING BATH



Our Beautiful Freestanding Bath Series are constructed of fibreglass reinforced acrylic are non slip and smooth to the touch.

SYDNEY

Woollahra

163 Edgecliff Road

Woollahra NSW 2025

T 02 9386 9809

Chatswood

Unit 36/28 Barcoo Street

Chatswood NSW 2067

T 02 9882 2044

MELBOURNE

Richmond

229 Swan Street

Richmond VIC 3121

T 03 9428 9996

QUEENSLAND

Fortitude Valley

Shop 2, 826 Ann St,

Fortitude Valley, QLD 4006

T 07 3852 6363

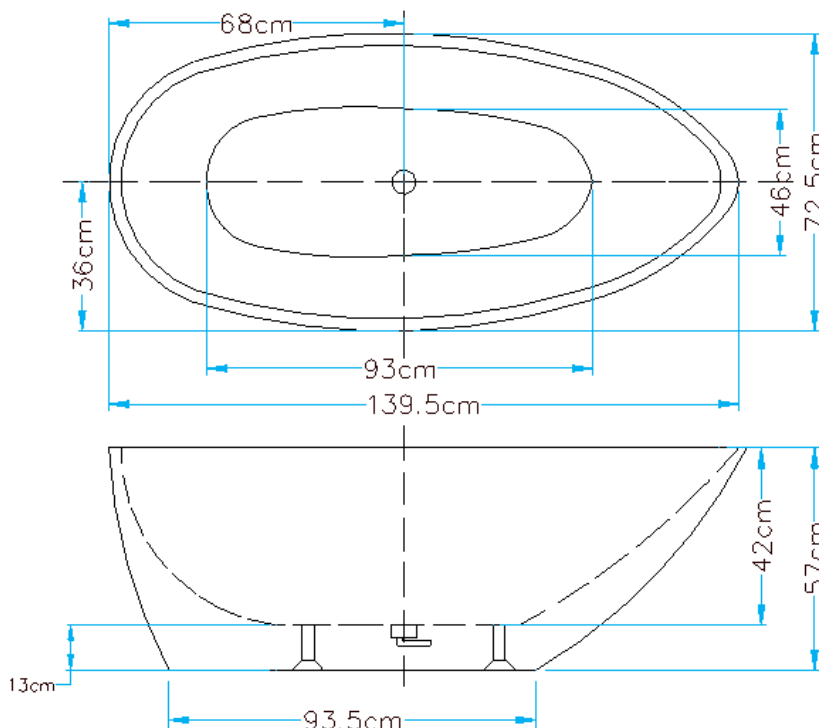

- Code: ST03D
- 25mm Profile 8mm Thick Acrylic reinforced with fibreglass
- 10yr Warranty
- Smooth gloss white finish
- Non Slip
- Polished chrome popup waste kit installed
- Adjustable galvanised metal legs for levelling
- 1mtr 40mm Flexible waste hose for easy installation
- Galvanised supporting under carriage
- Net Weight 65Kgs
- Crated size L+100, W+100, H+250mm
- Gross Weight 85kgs
- Australian Standard (SAI)
- AS/NZS 3718:2003



WaterMark
 LIC. WMKA00381
 SAI GLOBAL



www.acsbathrooms.com.au

As part of ACS commitment to quality products. Information provided in this data sheet is representative of the actual product available at the time of printing. Due to our commitment to continuous product design and development, the designs and specifications depicted are subject to change without notice. Please confirm all particulars with your ACS sales consultant prior to purchase. Each product is covered by a limited warranty. Please see our website for full terms and conditions. This drawing remains the property of ACS and should not be copied or distributed without ACS consent. © 2010 All Dimensions are approximate in mm and are not to scale.