

moda

Code: ST04A

Material: 8mm Reinforced Acrylic
Size: W 1800 x D 810 x H 550 mm
Warranty: 10 Years

Features:

- Seamless Technology
- Italian Design & Engineering
- Pop Up Waste Installed
- 40mm Flexible Hose for Easy Installation
- Galvanised Metal Base Support
- Adjustable Leg Height For Levelling
- Nonslip smooth gloss white finish
- Australian Standard (SAI)
AS/NZS 3718:2003

Mia

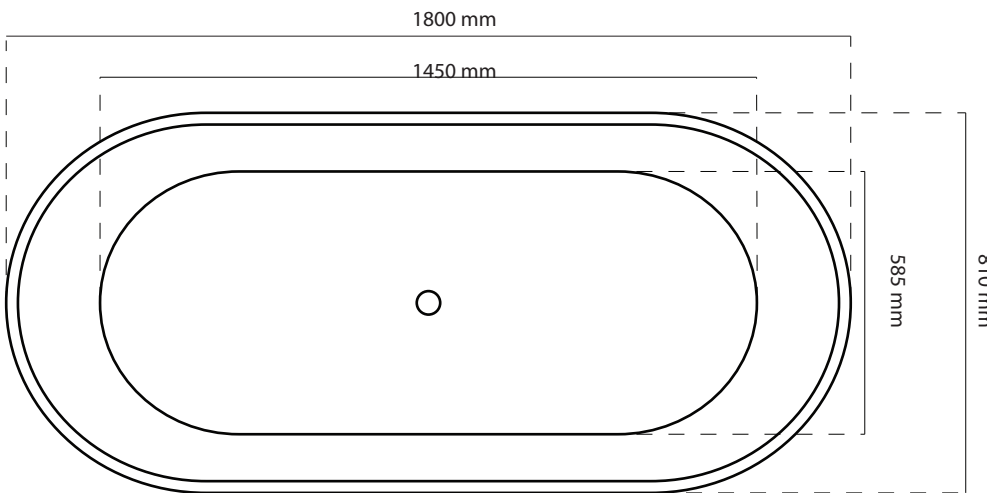

Specifications:

- Net Weight: 60 Kg
- Crate size:
L 1900, W 910, H 800mm
- Gross Weight: 85Kg

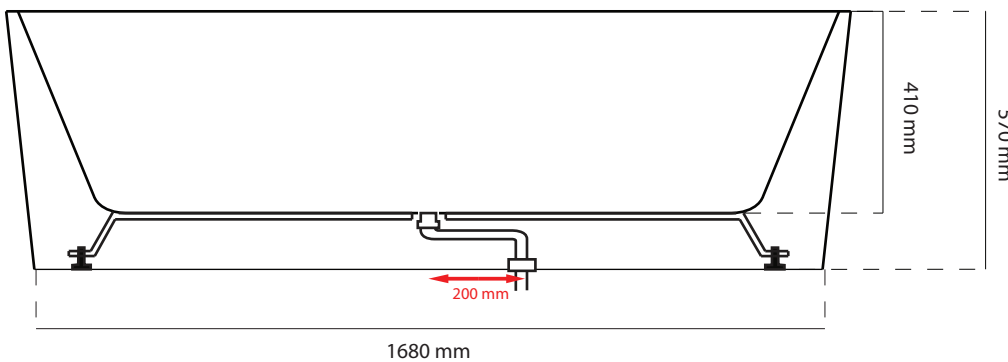

ACS

DESIGNER BATHROOMS

Woollahra NSW
163 Edgecliff Rd 2025
Ph: +61 2 9386 9809
Fax: +61 2 9386 9810

Crows Nest NSW
113a Willoughby Rd 2065
Ph: +61 2 9460 6111
Fax: +61 2 9460 6133

Richmond VIC
229 Swan St 3121
Ph: +61 3 9428 9996
Fax: +61 3 9428 9998