

# moda

**Code:** ST04F

**Material:** 8mm Reinforced Acrylic

**Size:** W 1300 x D 710 x H 550 mm

**Warranty:** 10 Years

## Features:

- Seamless Technology
- Italian Design & Engineering
- Pop Up Waste - Installed
- 40mm Flexible Hose for Easy Installation
- Galvanised Metal Base Support
- Adjustable Leg Height For Levelling
- Nonslip smooth gloss white finish
- Australian Standard (SAI)  
AS/NZS 3718:2003

## Mia

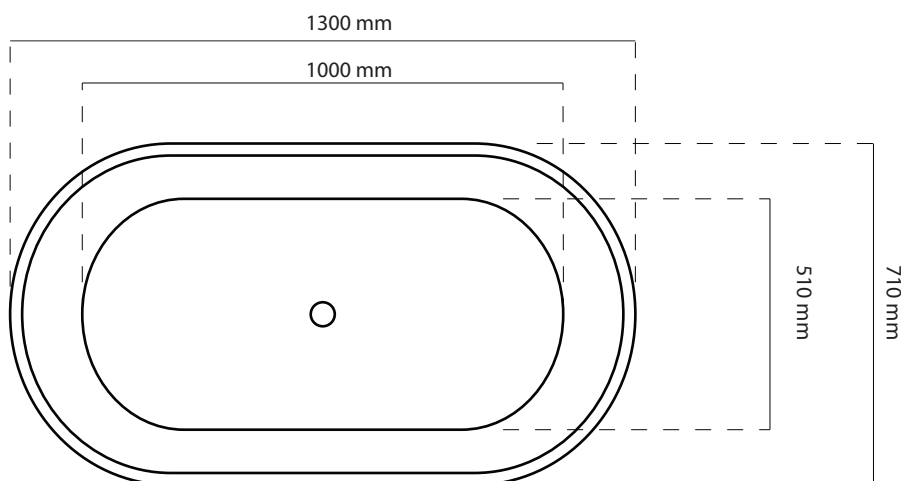

## Specifications:

- Net Weight: 60 Kg
- Crate size:  
L 1400, W 810, H 800mm
- Gross Weight: 85Kg

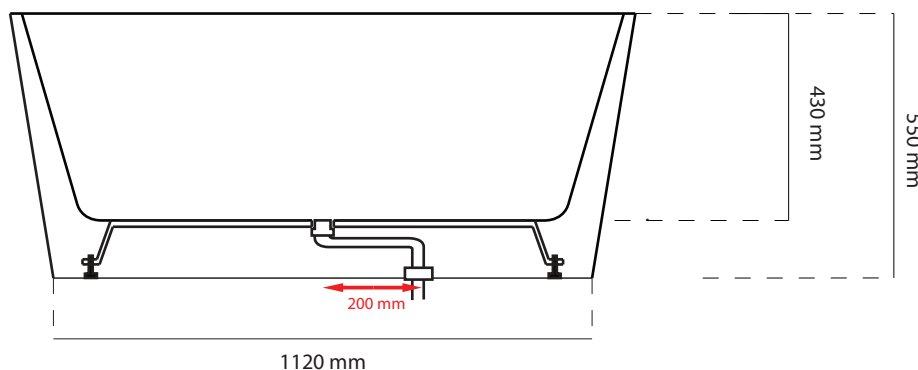

**ACS**  
DESIGNER BATHROOMS

1300 898 889

[www.acsbathrooms.com.au](http://www.acsbathrooms.com.au)