

# moda

**Code:** ST11

**Material:** 8mm Reinforced Acrylic

**Size:** W 1800 x D 860 x H 520 mm

**Warranty:** 10 Years

## Features:

- Seamless Technology
- Italian Design & Engineering
- Pop Up Waste - Installed
- 40mm Flexible Hose for Easy Installation
- Galvanised Metal Base Support
- Adjustable Leg Height For Levelling
- Nonslip smooth gloss white finish
- Australian Standard (SAI)

AS/NZS 3718:2003

## Ramon

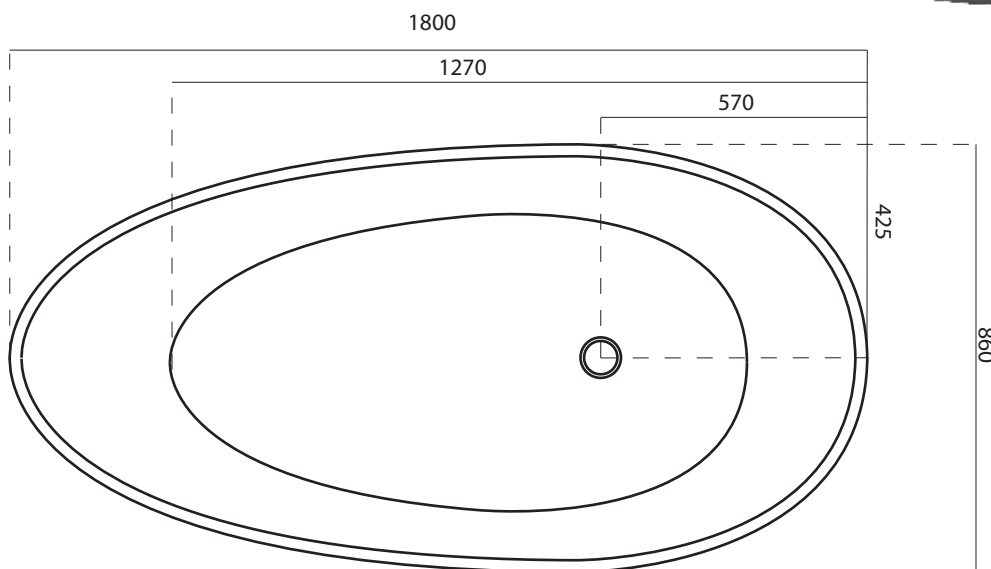

## Specifications:

- Net Weight: 65 Kg
- Crate size:  
L 1900, W 900, H 750mm
- Gross Weight: 90Kg
- Reasonable Manufacturing Tolerances Apply

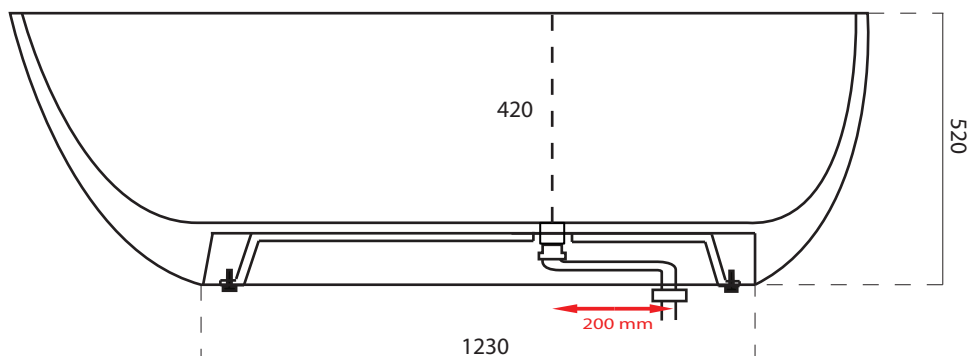

WaterMark  
LIC. WMKA00381  
SAI GLOBAL



Australian  
Standard

**ACS**  
DESIGNER BATHROOMS

1300 898 889

[www.acsbathrooms.com.au](http://www.acsbathrooms.com.au)